

# BOLT BAG #LP41170 LP1050A ALUMINUM LADDER LOW PRO DOCKS

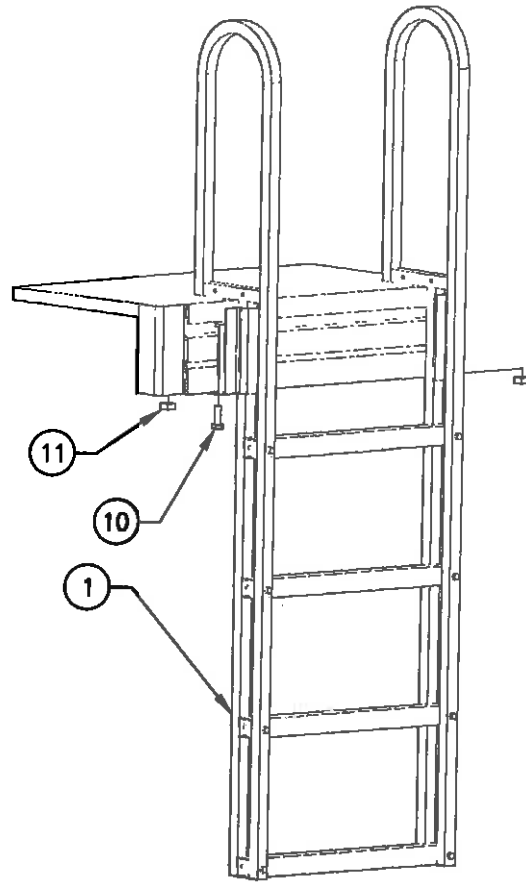

955 INDUSTRIAL ST. N.E. PINE CITY, MN 55063  
320-629-6737 (OFFICE) 320-629-3677 (FAX)  
www.dokadock.com

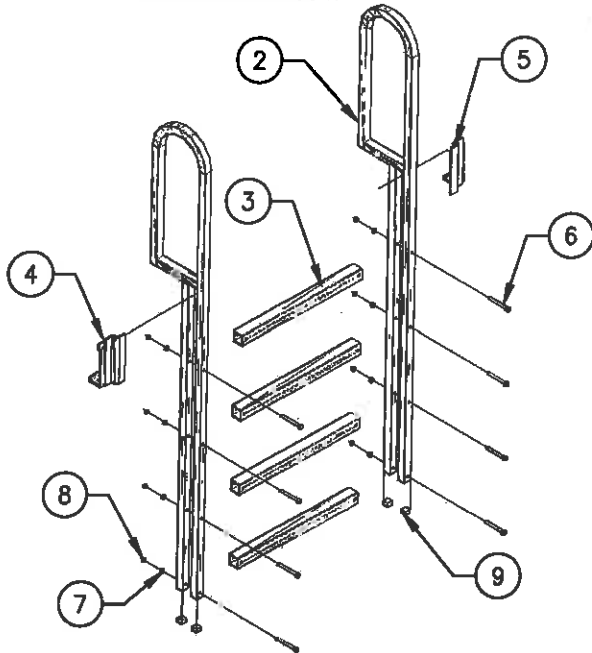

KEY#	DESCRIPTION	PART#	QUANTITY
1.	4 RUNG LADDER	1050A	1
2.	LADDER SIDE FRAME 4 RUNG	80831048	2
3.	LADDER RUNG	80830916	4
4.	LADDER MOUNT BRACKET LH	85851050L	1
5.	LADDER MOUNT BRACKET RH	85851050R	1
<b>BOLT BAG #LP41170</b>			1
6.	MACHINE SCREW (BOLT) 1/4" X 3 3/4"	SCM14334	8
7.	FLAT WASHER	FW14SAE	8
8.	CAP NUT 1/4"	CPN14	8
9.	PLASTIC CAP FOR SIDE FRAME	82831165	4
10.	HEX BOLT S.S. 1/2" X 1 1/2"	HBSS12112	2
11.	NUT SQUARE 1/2" BRASS	NS12BRASS	2

## ASSEMBLY INSTRUCTIONS FOR 4 RUNG ALUMINUM LADDER

- Slide rungs (Key 3) into ladder side frames (Key 2) watching so holes line up.
- Use 1/4 x 3-3/4 machine screws/bolts (Key 6), flat washers (Key 7) and cap nuts (Key 8) to secure rungs to front of ladder. NOTE: Head of bolts to front of ladder, flat washers and cap nuts to rear (inside) of ladder. Tighten nuts.
- Install plastic caps (Key 9) in bottom of side frame.

## MAINTENANCE

- Whenever ladder is out of the water, routinely clean ladder rungs to reduce slipperiness.
- Designed for easy removal and installation, remove ladder when not in use for long periods. We recommend removing ladder before removing dock from water; this will help reduce chances of ladder being damaged due to ground clearance issues.
- Annually inspect all nuts and bolts for deterioration and tightness. Replace and/or tighten if necessary.

4/25/14

PAGE 1 OF 1