

WHEEL END ASSEMBLY MANUAL

DAKA Truss-Style Docks

WHEEL END KITS: 1945A/G/P, 1955A/G/P, 1960A/G/P



Straight Dock



Platform Dock



Super Platform Dock



DAKA Corporation

955 Industrial St. N.E. • Pine City, Minnesota 55063

Phone: 320-629-6737 • Fax 320-629-3677

www.dakadock.com



LIMITED WARRANTY

DAKA Corporation warrants its boat docks and boat lift components purchased new by the original owner to be free of defects in material or workmanship, from the date of sale for the periods of time set forth below:

- New DAKA-built aluminum boat docks and lifts carry a 15-year conditional warranty on all aluminum and aluminum welds, and a 5-year pro-rated warranty on canopy tops, excluding fading.
- New DAKA-built steel boat docks carry a 10-year conditional warranty on steel and steel welds. There is no warranty on paint and/or finish.

DAKA Corporation further warrants all other parts, excluding wood, used on DAKA-built lifts, boat docks and accessories, purchased new by original owner, to be free from defects in the material and workmanship under normal use for a period of 24 months from the date of purchase (excluding components and options which carry their own manufacturer's warranty, wherein that warranty will apply). Excluded from this warranty are all paint and/or finishes, and wood decking. There is no other expressed warranty. DAKA Corporation is not liable for incidental or consequential damages or injuries of any kind due to installation, removal, use, misuse, snow or ice, electrolysis, severe weather, acts of God, misapplication, or improper selection of one of our purchased or displayed products. DAKA agrees to repair or replace only defective parts returned to the factory (prepaid) and deemed defective by DAKA. Warranty is void when misuse or neglect is the cause. Specifications are subject to change without notice.

DAKA is not responsible for removal, dismantling or reinstallation cost. This warranty is void if the boat lift or dock is used in other-than-normal residential service, or installed in salt water. For commercial boat dock and lift warranty, see Commercial Warranty.

For services under this warranty, contact selling dealer or DAKA Corporation, Customer Service Department, 955 Industrial Street NE, Pine City, Minnesota 55063; Telephone (320) 629-6737.

Implied warranties including that of merchantability are expressly limited in duration of this warranty. DAKA Corporation disclaims any liability for incidental or improper selection, removal, use, misuse, misapplication, neglect or improper selection of our product. Some states do not allow limitations on how long an implied warranty lasts, or the exclusion or limitation of incidental or consequential damages so this limitation and exclusion may not apply to you.

This warranty gives you specific legal rights, and you may also have other rights, which vary from state to state.

This is our exclusive written warranty.

Effective 09/03
Revision 1: 11/1/07

TOOLS NEEDED:

- 1/2", 9/16", 3/4" Box Wrenches
- 1/2", 9/16", 3/4" Socket Wrench and Sockets

CHECK FOR MISSING ITEMS OR ITEMS DAMAGED IN SHIPMENT

Unpack all items from the shipping cartons, bags and pallets. Locate the parts List. Compare the items received with the parts list. Report any missing/damaged items to DAKA Corporation 800-884-3252.

TABLE OF CONTENTS: Aluminum (A) / Galvanized Steel (G) / Painted Steel (P)

Warranty.....	3
Component Identification.....	4
Straight Wheel End Section Assembly (1945 A / G / P).....	5-9
Platform Wheel End Section Assembly (1955 A / G / P).....	10-13
Super Platform Wheel End Section Assembly (1960 A / G / P).....	14-16
Connect Platform to Dock Sections.....	17
Rolling Dock Assembly into Water and Installation Tips.....	18, 19

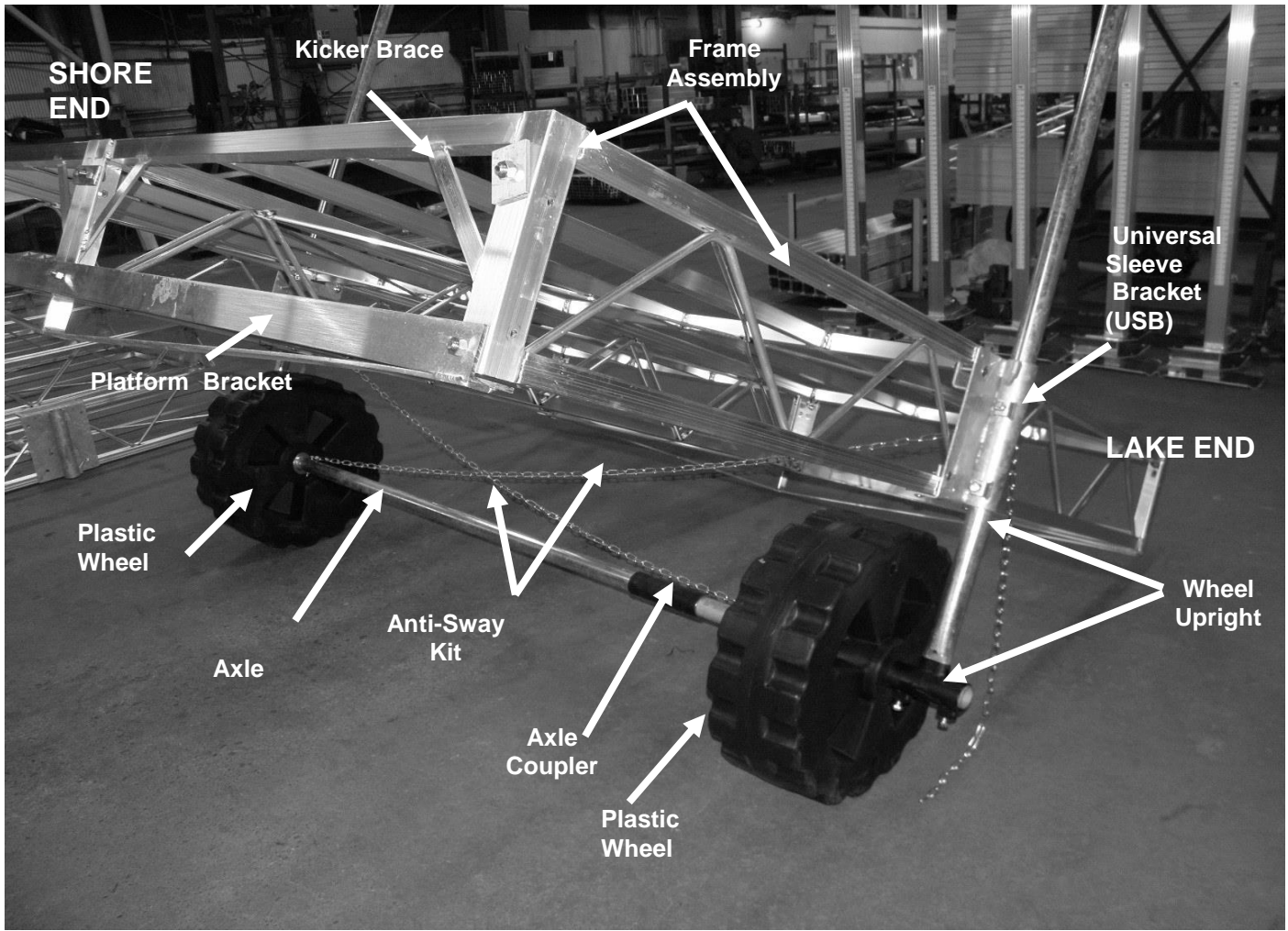

PART IDENTIFICATION

A good understanding of part names and shapes will greatly speed the assembly process.

Locate a level surface and unpack items. Review part identification on hardware packaging and above components. Do not proceed with assembly until you have a good understanding of part identification.

PICTURE IDENTIFICATION

The pictures in this manual show DAKA's Aluminum Truss-Style dock frames. The same assembly procedure is used for both Aluminum and Steel docks. The only difference is the installation of the sleeve brackets on the side of the frame. See page 6 & 7.

STRAIGHT WHEEL END ASSEMBLY (1945A/G/P KITS)

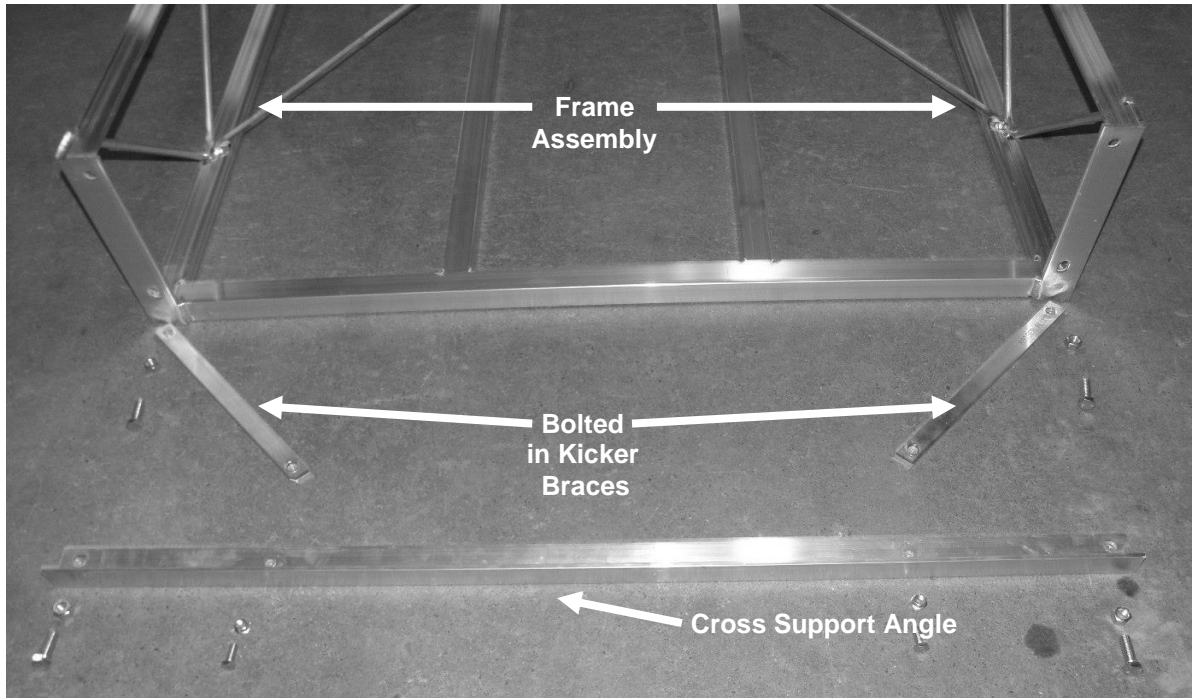

FIG. 1: Frame Components (Frame pictured upside down)

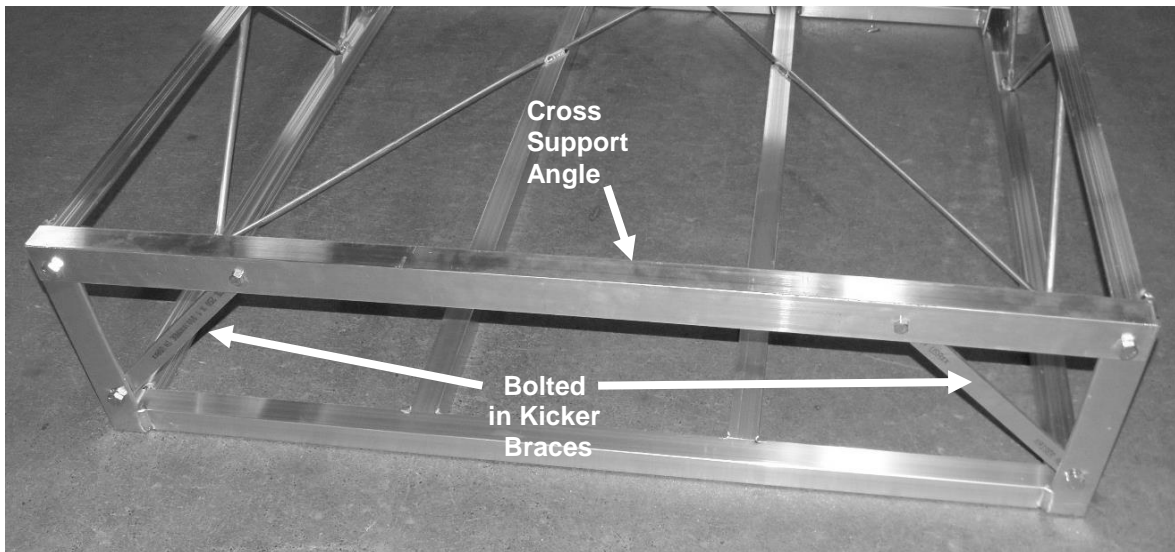

FIG. 2: Frame Brace Components Installed (Frame pictured upside down)

INSTALL CROSS SUPPORT ANGLE

NOTE: When assembling a section that will be used as a Straight Wheel End, a Cross Support Angle will need to be installed on the 4 foot open end of the dock frame opposite of the end with welded Kicker Braces. Place a Frame Assembly upside down on a flat surface. See FIG. 1.

Locate 2 ea. Bolted In Kicker Braces, 1ea. Cross Support Angle. See FIG. 1.

INSTALL THE 2 ea. Bolted In Kicker Braces on the inside of the Cross Support Angle with 2 ea. 3/8" x 1" hex bolts and 2 ea. 3/8" flange nuts. See FIG. 2. Install the Cross Support Angle and Bolted-in Kicker Braces to the Frame Assembly using 4 ea. 1/2" x 1-1/2" hex bolts and 4 ea. 1/2" hex nuts. See FIG. 2. Firmly tighten all hardware.

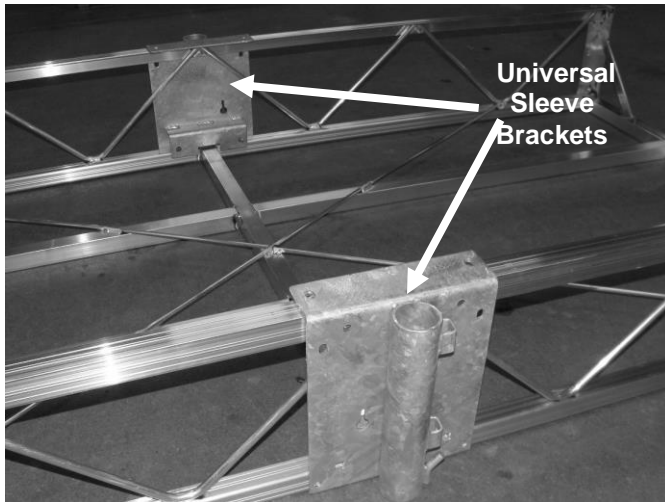

FIG. 3: Universal Sleeve Brackets *

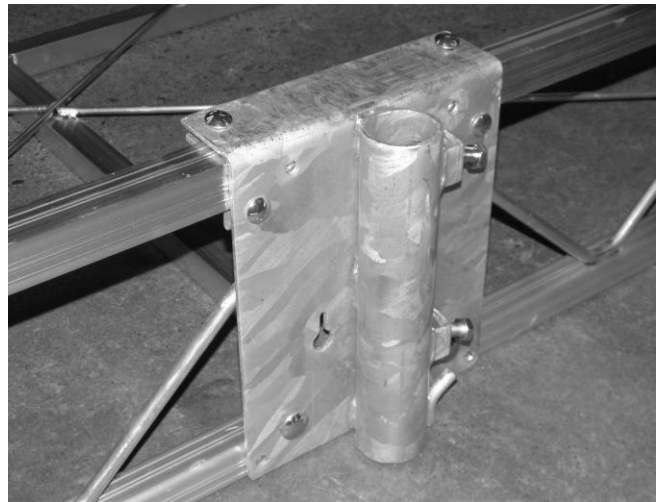

FIG. 4: Outside View of One Bracket *

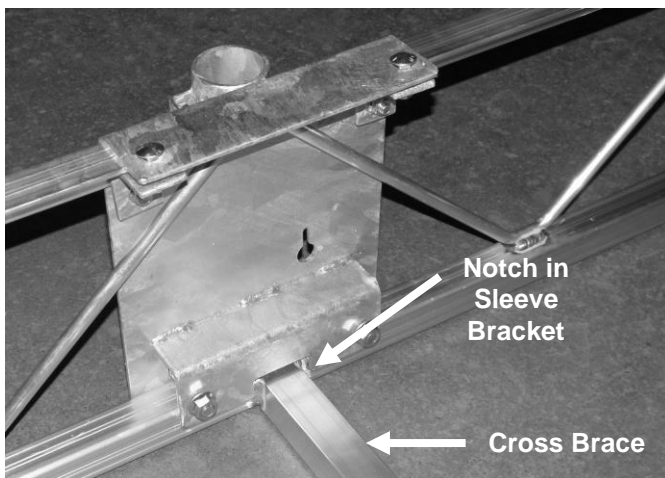

FIG. 5: Inside View of One Bracket *

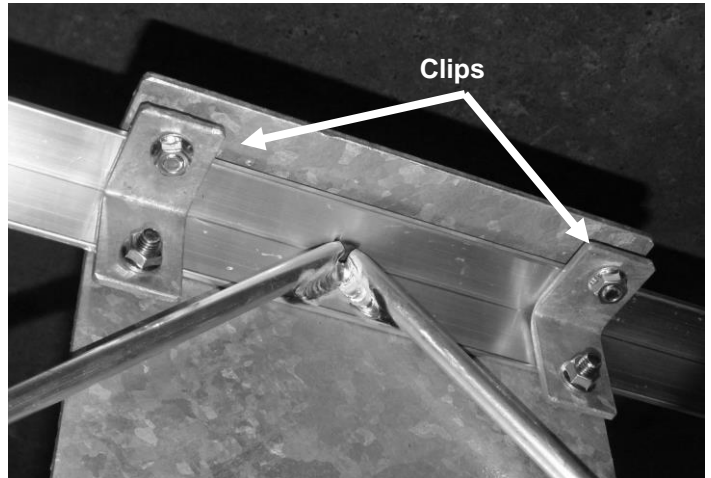

FIG. 6: Underside View of Upper Mounting Clips *

*** Note the Frame Assembly shown in FIGS: 3-6 is placed upside down for ease of assembly.**

ALUMINUM DOCK FRAMES: INSTALL UNIVERSAL SLEEVE BRACKETS (USB)

For ease of assembly, the Frame Assembly is laying upside down on a flat surface. See FIG. 3. Install the 2 ea. Universal Sleeve Brackets in the center of the section as shown in FIGS. 3-6. Note how the notch in the bracket fits into the Center Cross Brace of the frame assembly. See FIG. 5.

Use 2 ea. 1/2" x 1-1/2" carriage bolts and 2 ea. 1/2" flange nuts for the lower hardware. Finger tighten only at this time. See FIG. 5.

Use 4 ea. 3/8" x 1-1/4" carriage bolts, 4 ea. 3/8" flange nuts and 2 ea. mounting clips for the upper hardware. Finger tighten only at this time. See FIG. 6.

Firmly tighten all hardware when USB Bracket is correctly assembled onto the frame.

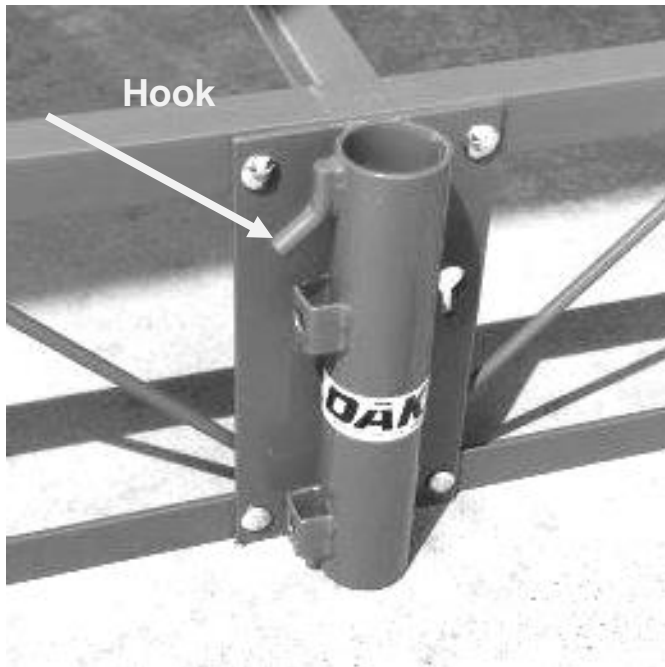

FIG. 6A: Steel Sleeve Bracket

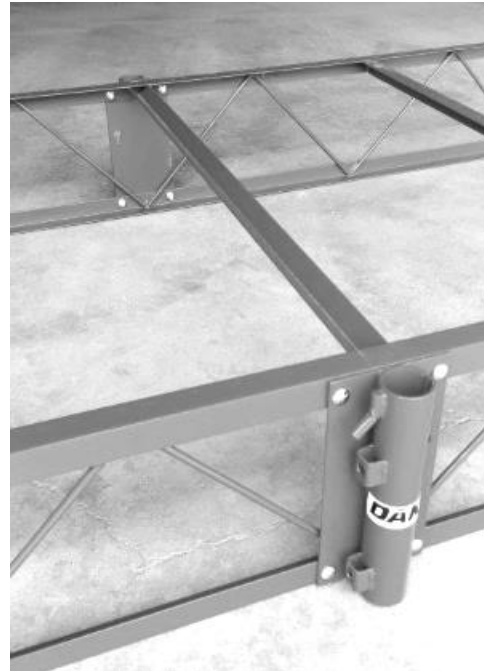

FIG. 6B: Steel Sleeve Brackets

**STEEL DOCK FRAMES ONLY (PAINTED & GALVANIZED):
INSTALL UPRIGHT SLEEVE BRACKETS**

Install the (2) ea. Upright Sleeve Brackets in the center of the section as shown in FIG. 6B. Note that the sleeve is turned the correct way so the hook is at the top side of the frame.

Use (4) ea. 3/8" x 1" carriage bolts and (4) ea. 3/8" flange nuts to mount each sleeve to frame. Install all (4) ea. bolts before tightening.



FIG. 7: Stand Assembly Upright

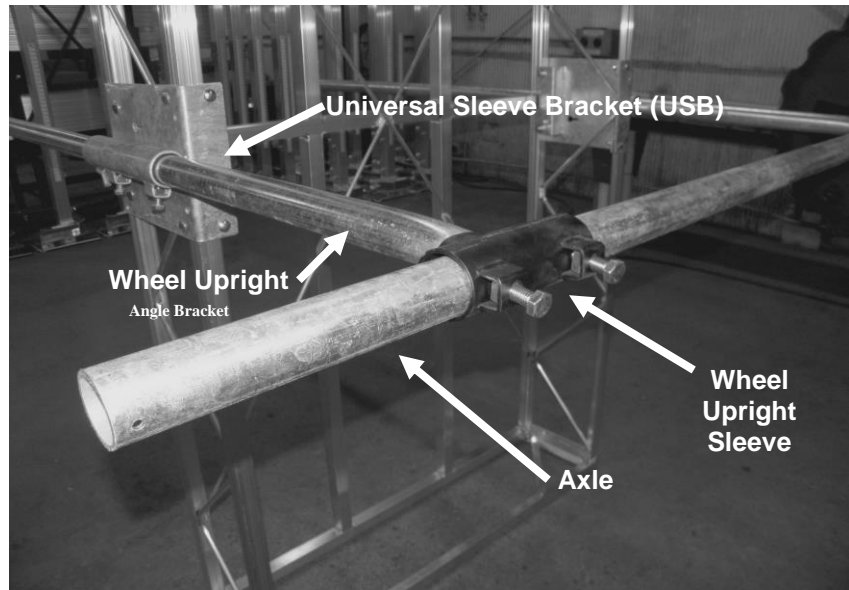

FIG. 8: Install Wheel Upright and Axle

INSTALL WHEEL UPRIGHTS AND AXLE

Stand the Frame Assembly upright on its end. See FIG. 7. It is recommended to have a second person continue holding the Frame Assembly in this position while you install the rest of the wheel components. Slide each Wheel Upright into the Universal/Upright Sleeve Bracket. See FIG. 8. Insert two $\frac{1}{2}$ " square nuts into the nut cages on side of Universal/Upright Sleeve Bracket. Install two hex bolts $\frac{1}{2}$ " x $1\frac{1}{2}$ " in the square nut cage. Finger tighten bolts at this time. Repeat on other side of the frame assembly.

Remain holding the Wheel End Section in the standing position. Slide the Axle (See FIG. 8) through both Uprights. Install two hex bolts $\frac{1}{2}$ " x $1\frac{1}{2}$ " in the square nuts on each Universal/Upright Sleeve and finger tighten onto the Axle.

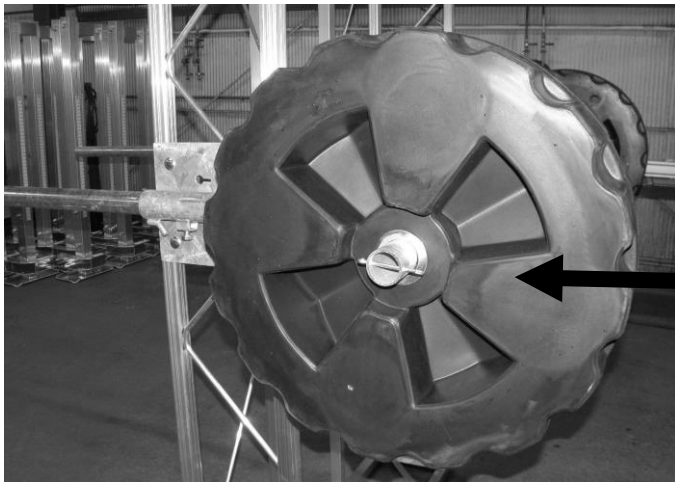

FIG. 9: Wheel Installed on Axle *

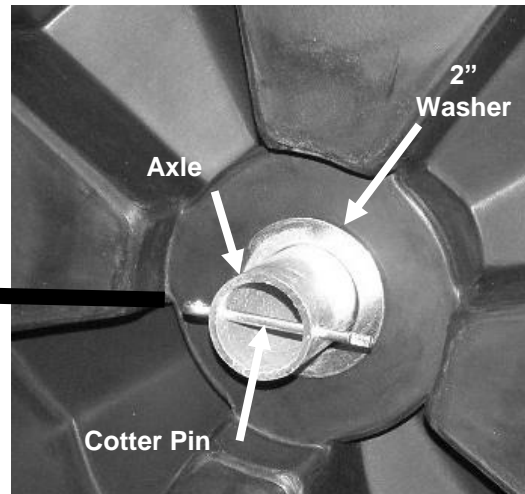

FIG. 10: Close Up of Wheel/Axle Installation

***NOTE:** The wheels are mounted on the outside of the Straight Wheel End Dock Frames.

INSTALL PLASTIC WHEELS AND AXLE

Install a Plastic Wheel Assembly on the end of the Axle. See FIGS. 9-10. Install the 2" Washer next to the plastic wheel. Secure the cotter pin. See FIG. 10. Make sure the washer is between the cotter pin and the wheel. This will prevent the cotter pin from damaging the plastic wheel. Repeat this step on the other end of the axle, installing a plastic wheel, 2" washer and cotter pin.



FIG. 11: Backside of Wheel Installed on Axle



FIG. 12: Outside View of Wheel Installed on Axle

ADJUST HEIGHT OF WHEEL ASSEMBLY

Slide the Axle and Wheel Assembly side to side until centered between the Upright Sleeves. Firmly tighten the Upright Sleeve Bolts on both sides. See FIG. 11.

Later when your dock assembly is ready to move into the water, you will adjust the height of the dock as needed to keep the frame and deck surface above water at the wheel location. For now, slide the axle assembly down until there is a 2 inch gap between the top of the wheels and the bottom of the frame assembly. Firmly tighten the Universal/Upright Sleeve Bracket set bolts. See FIG. 12.

Your Straight Wheel End Assembly is now complete.

PLATFORM ASSEMBLY (1955A/G/P KITS)

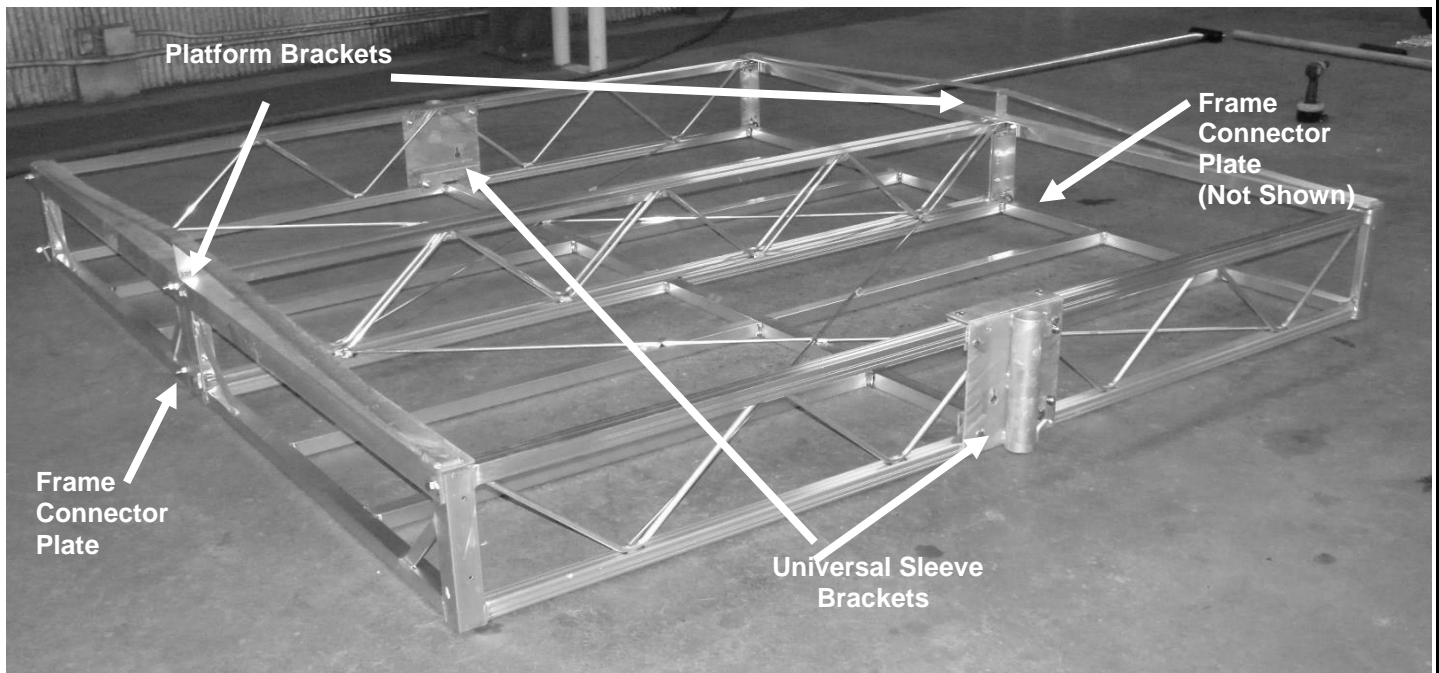

FIG. 13: Frame Assembly Components (Shown on assembled frames and upside down.)

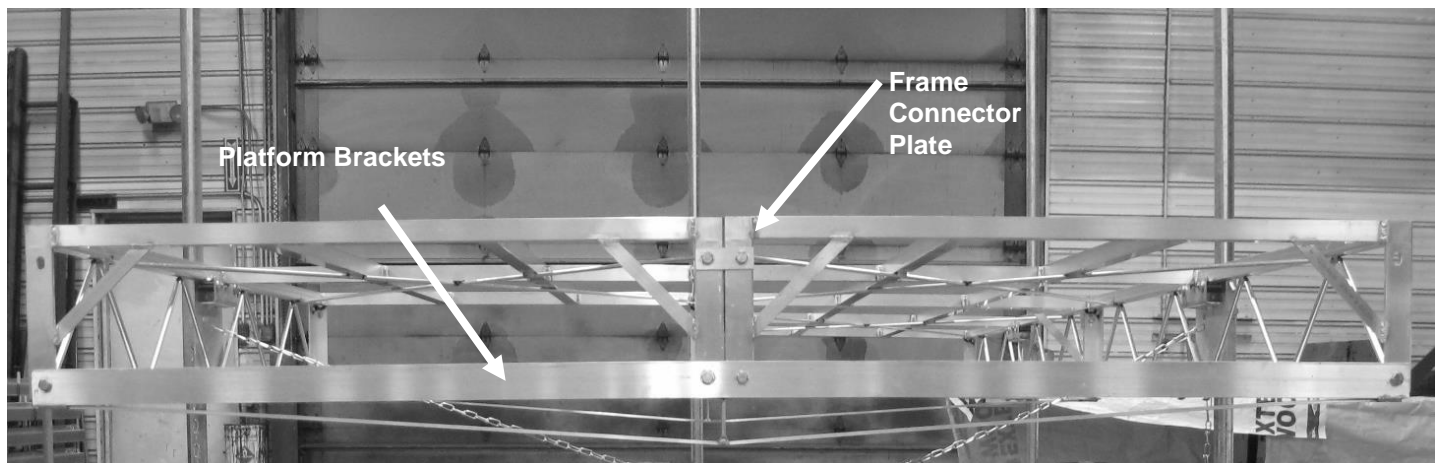

FIG. 14: Frame Assembly Components (Shown on fully assembled dock and right side up.)

CONNECT TWO FRAME ASSEMBLIES AND INSTALL BRACING

Lay two Frame Assemblies upside down and side by side on a flat level surface. See FIG. 13.

Install a Platform Bracket to the frame on each end using 4 ea. hex bolts $\frac{1}{2}$ " x $1\frac{1}{2}$ " and 4 ea. $\frac{1}{2}$ " hex nuts on each end. Only finger tighten hardware at this time. See FIG. 13-14.

Install 2 ea. Connector Plates on each end of the Frame Assemblies (See FIG. 13 & 14) using 2 ea. hex bolts $\frac{1}{2}$ " x $1\frac{1}{2}$ " and 2 each $\frac{1}{2}$ " hex nuts on each end. Finger tighten all hardware at this time. See FIG. 13. When fully assembled, firmly tighten all hardware.

INSTALL UNIVERSAL / UPRIGHT SLEEVE BRACKETS

Install 2 ea. Universal/Upright Sleeve Brackets in the center of the section as shown in FIG 13. Refer to detailed instructions on page 6 & 7. Firmly tighten all hardware when bracket is correctly assembled onto the frame.

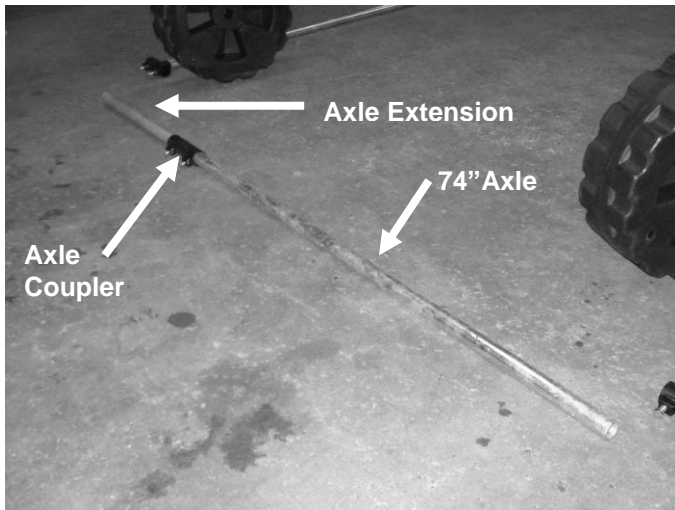

FIG. 15: Axle Components

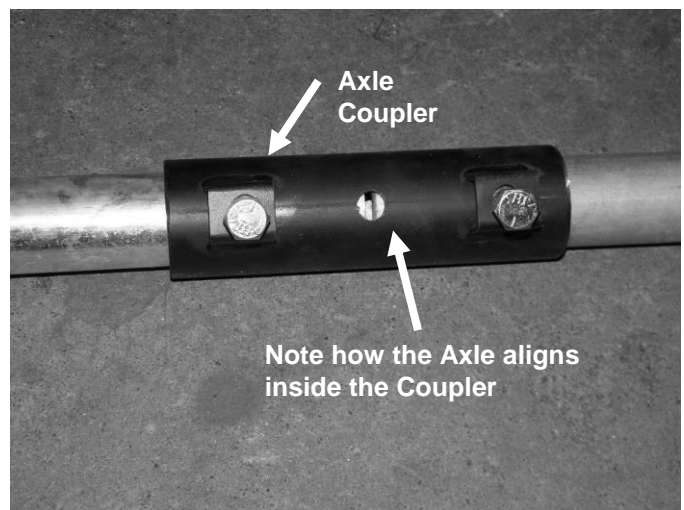

FIG. 16: Close Up of Axle Coupler

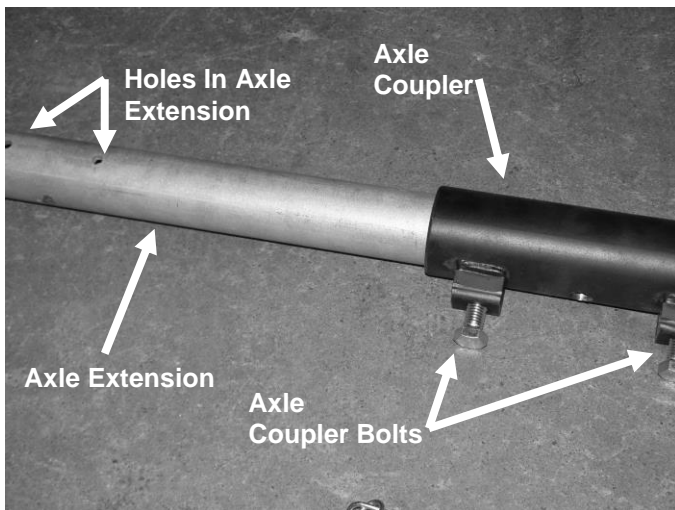

FIG. 17: Axle Components

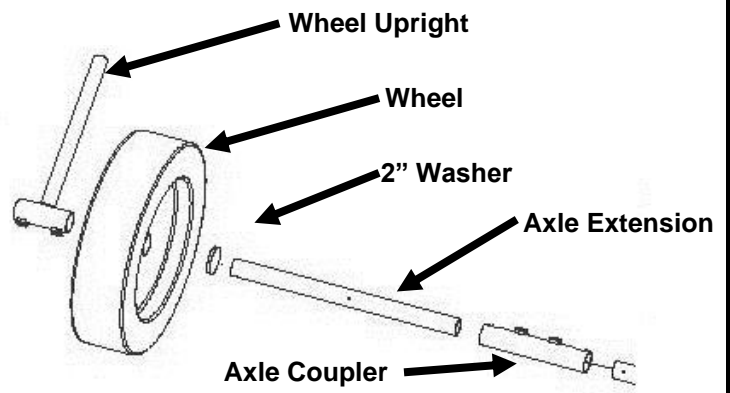

FIG. 18: Axle Assembly Components

ASSEMBLE THE AXLE COMPONENTS

Locate the short axle, 74" Axle, Axle Extension and the Axle Coupler. See FIG. 15. Assemble as shown in FIG. 16. Finger tighten at this time. Note in FIG. 16 how the two pipe ends join inside the Coupler with a slight gap. Also note in FIG. 17 the position of the two holes in the Axle Extension in relationship to the Axle Coupler bolts. It is important that these items are assembled as you see them positioned in FIGS. 17-18. When the items are correctly positioned, firmly tighten all axle hardware.

NOTE: Wheels are located under the dock on Platform and Super Platform Wheel End Docks.

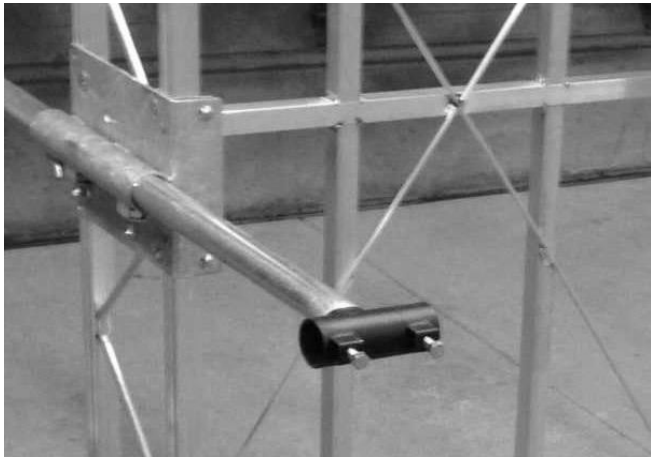

FIG. 19: Wheel Upright Pole

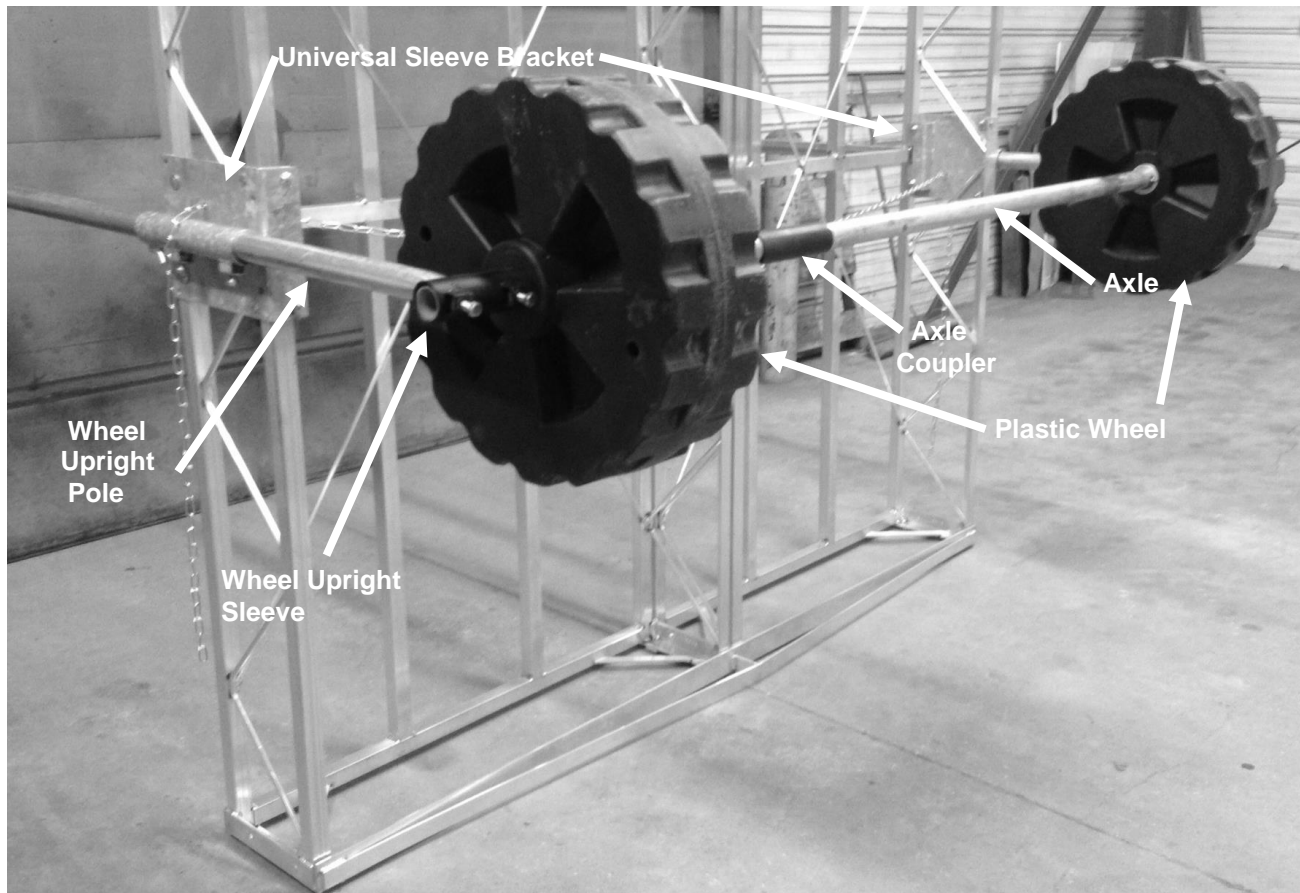

FIG. 20: Platform Assembly Components (Shown fully assembled)

INSTALL WHEEL UPRIGHT POLES

Stand the Frame Assembly Upright on its end. See FIG. 20. It is recommended to have a second person continue holding the frame assembly in this position while you install the rest of the wheel components. Slide each Wheel Upright Pole into the Universal/Upright Sleeve Bracket. See FIG. 19. Insert two ½” square nuts into the nut cages on side of the Universal/Upright Sleeve Bracket Assembly. Install two hex bolts ½” x 1-½” in the square nut cage. Finger tighten bolts. Repeat on other side of the frame assembly.

NOTE: Wheels are located under the dock on Platform & Super Platform Wheel End Docks.

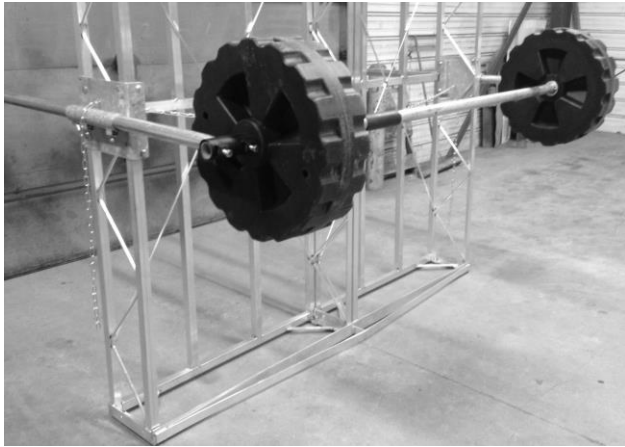

FIG. 21: Wheel/Axle Installation

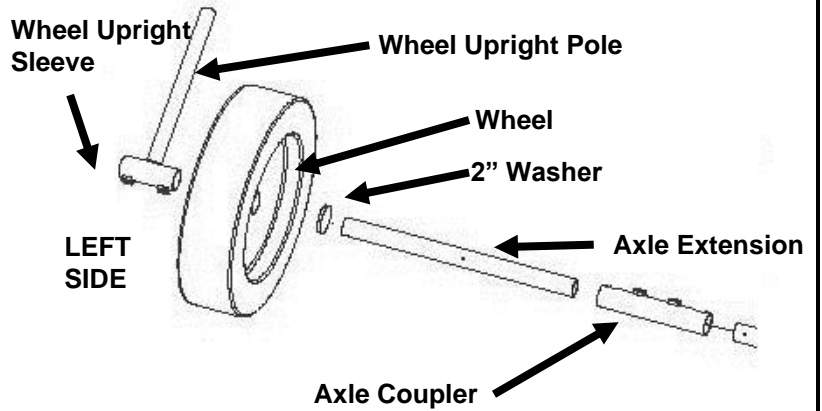

FIG. 22: Wheel/Axle Installation

INSTALL PLASTIC WHEELS AND AXLE

Have a second person hold the frame assembly in the upright position. While the axle is on the ground, pick up the left end of the axle, slide on a 2" washer and then a plastic wheel. Lift up the right end of the axle, slide on a 2" washer and then a plastic wheel. Slide each end of the axle into the upright sleeves. See FIG. 21, 22.

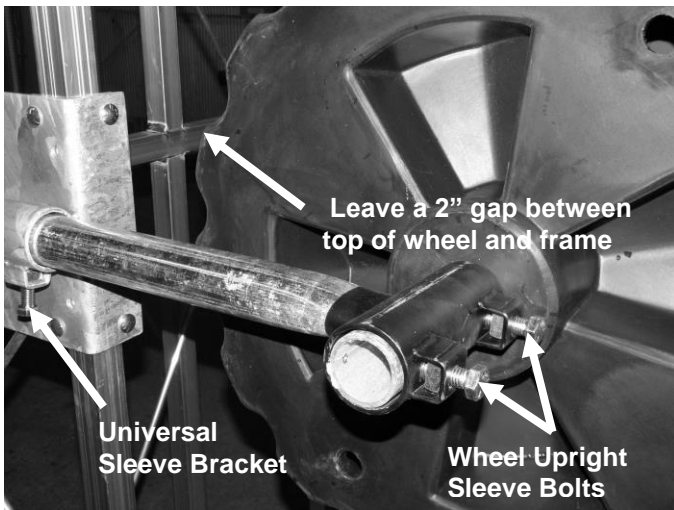

FIG. 23: Outside of Wheel Installed on Axle

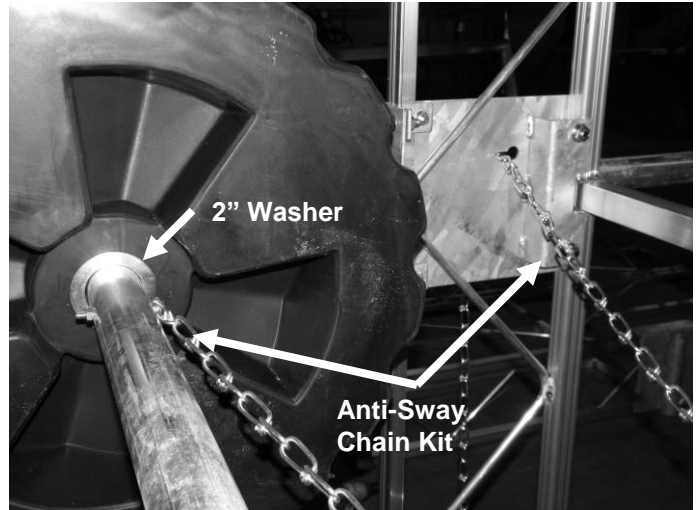

FIG. 24: Backside of Wheel Installed on Axle

ADJUST HEIGHT OF WHEEL ASSEMBLY

Slide the Axle and Wheel Assembly side to side until centered between the two Wheel Upright Sleeve Brackets. The ends of the Axle should be flush with the outside edges of the Wheel Upright Sleeve Bracket. See FIG. 23. Firmly tighten the Upright Sleeve set bolts onto the Axle. See FIG. 23. Before lowering the Frame Assembly down onto the wheels, firmly tighten the Universal/Upright Sleeve Bracket Bolts. See FIG. 23.

Note: The Anti-Sway Chain Kit will help eliminate side to side sway in the dock. See FIG. 24.

Your Platform Assembly is now complete.

SUPER PLATFORM ASSEMBLY (1960A/G/P KITS)

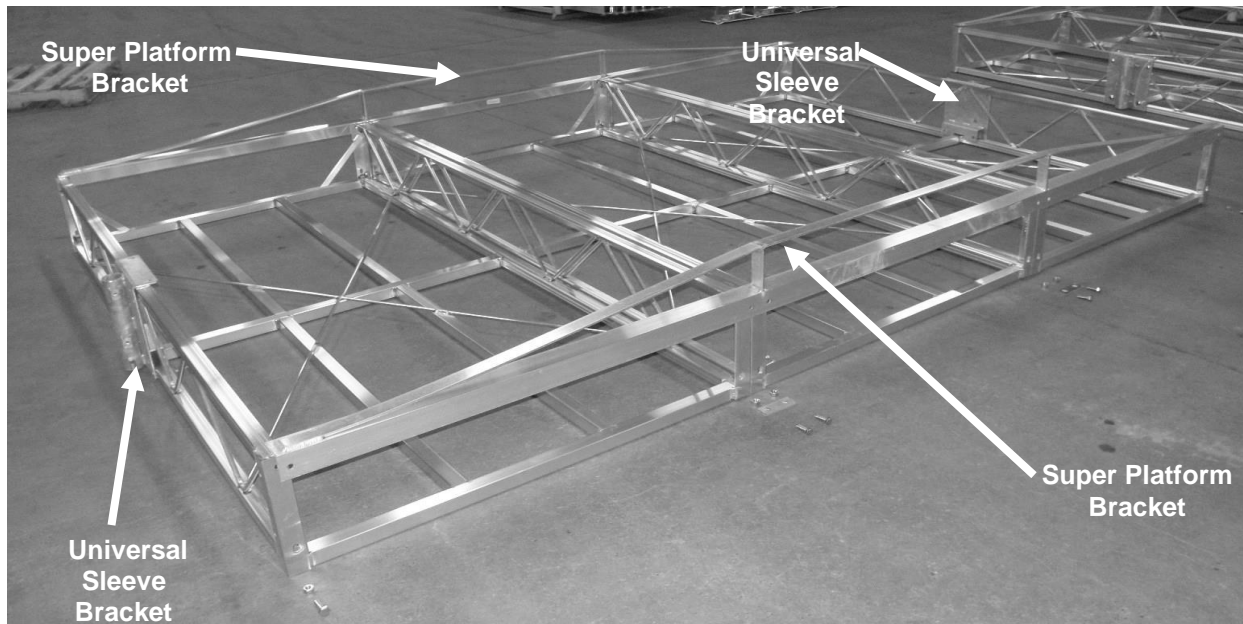

FIG. 25: Frame Assembly Components
(Shown partially assembled frames and upside down)

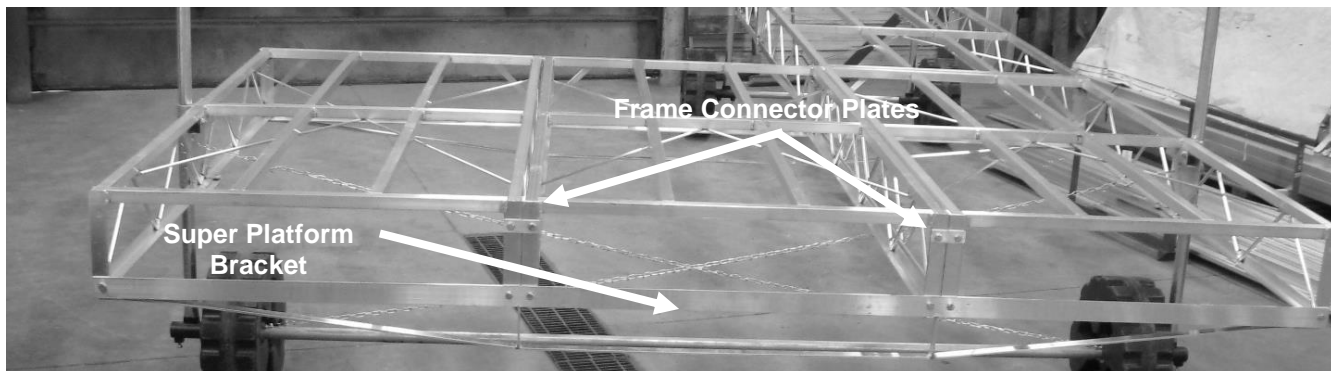

FIG. 26: Frame Assembly Components
(Shown on fully assembled dock and right side up.)

CONNECT TWO FRAME ASSEMBLIES AND INSTALL BRACING

Lay 3 ea. frame assemblies upside down and side by side on a flat level surface. See FIG. 25. Install a Super Platform Bracket to the frame on each end using 6 ea. hex bolts $\frac{1}{2}$ " x $1\frac{1}{2}$ " and 6 ea. $\frac{1}{2}$ " hex nuts on each end. Only finger tighten hardware at this time. See FIGS. 25-26.

Install 2 ea. connector plates on each end of the frame assemblies (See FIGS. 25, 26) using 4 ea. hex bolts $\frac{1}{2}$ " x $1\frac{1}{2}$ " and 4 ea. $\frac{1}{2}$ " hex nuts on each end. Finger tighten all hardware at this time.

When fully assembled, firmly tighten all hardware.

INSTALL UNIVERSAL / UPRIGHT SLEEVE BRACKETS

Install the 2 ea. Universal/Upright Sleeve Brackets in the center of the section as shown in FIG. 25. Refer to detailed instructions on Page 6 & 7. Firmly tighten all bracket hardware when the bracket is correctly assembled onto the frame.

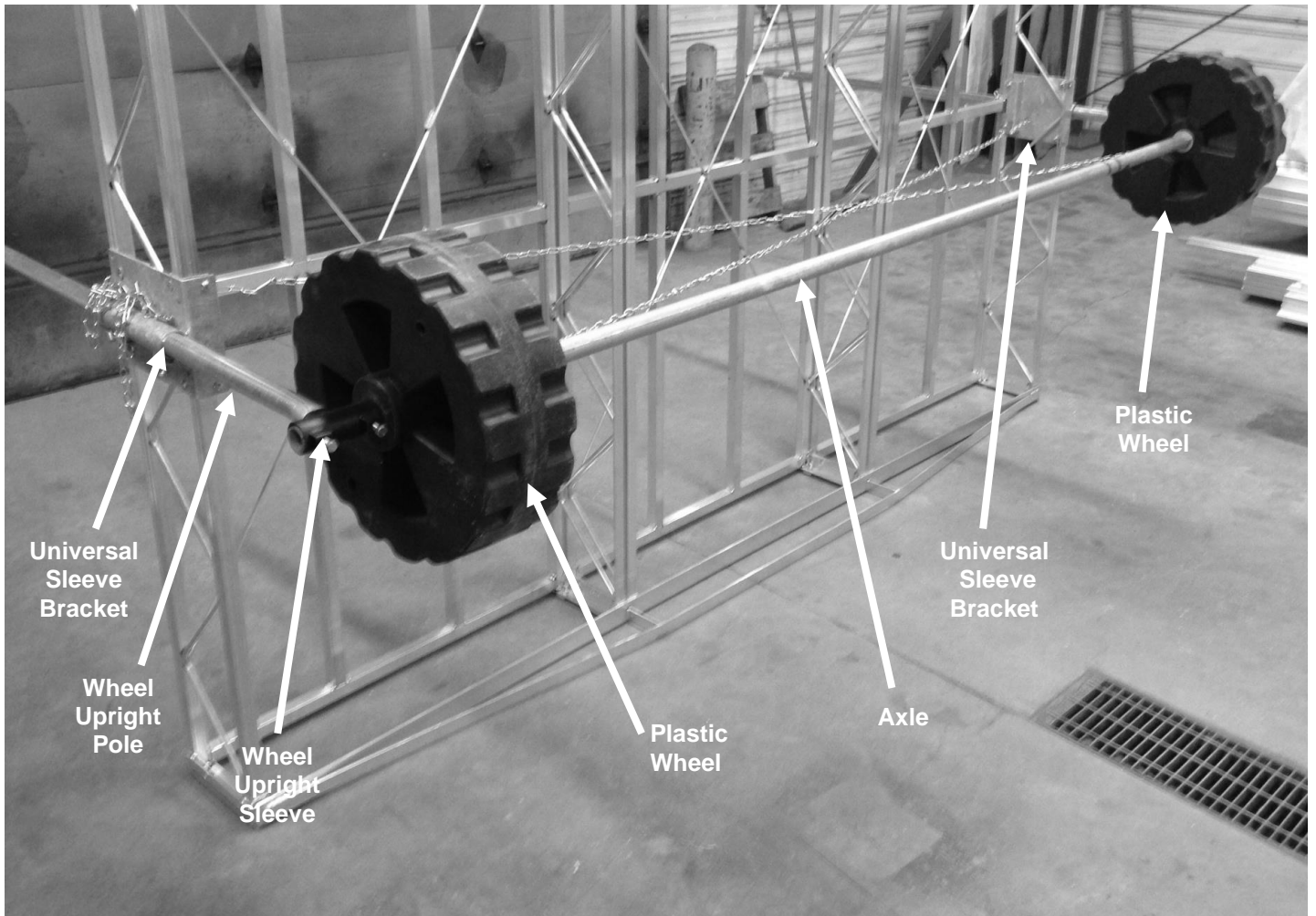

FIG. 27: Super Platform Assembly Components (Fully assembled)

INSTALL WHEEL UPRIGHT POLES

Stand the Frame Assembly upright on its end. See FIG. 27. It is recommended to have a second person continue holding the Frame Assembly in this position while you install the rest of the wheel components. Slide each Wheel Upright Pole into the Universal/Upright Sleeve Bracket. See FIG. 19 and 27. Insert (2) ½” square nuts into nut cages on side of Sleeve Assembly. Install (2) hex bolts ½” x 1-½” in square nut cage. Finger tighten only at this time. Repeat on other side of the Frame Assembly.

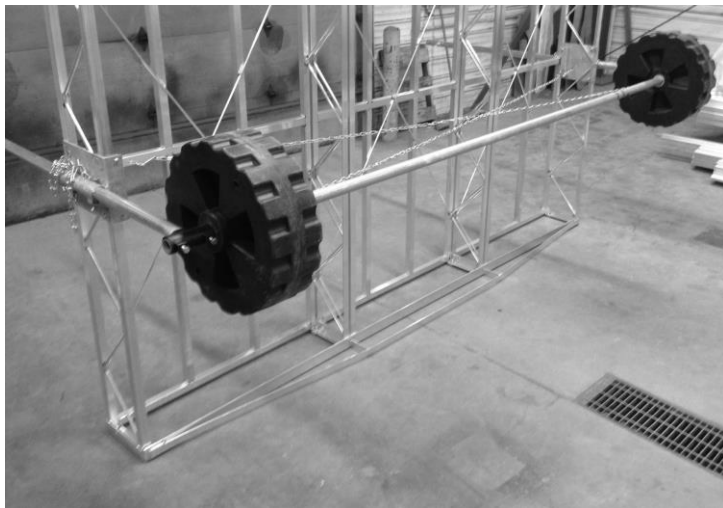

FIG. 28: Wheel/Axle Installation

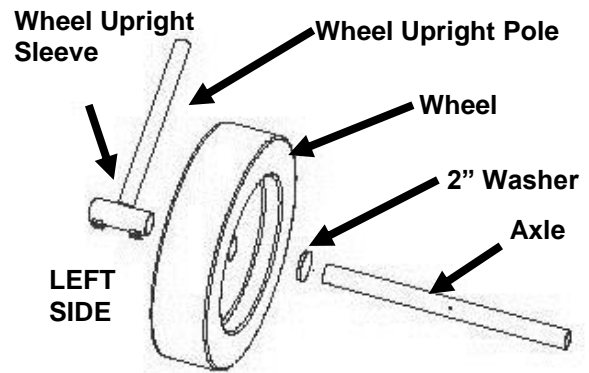

FIG. 29: Wheel/Axle Installation

INSTALL PLASTIC WHEELS AND AXLE

Have a second person hold the frame assembly in the upright position. While the axle is on the ground, pick up the left end of the axle, slide on a 2" washer and then a plastic wheel. Lift up the right end of the axle, slide on a 2" washer and then a plastic wheel. Slide each end of the axle into the two wheel uprights. Install two hex bolts $\frac{1}{2}$ " x $1\frac{1}{2}$ " in the square nuts on each wheel upright sleeve and tighten firmly onto the axle.

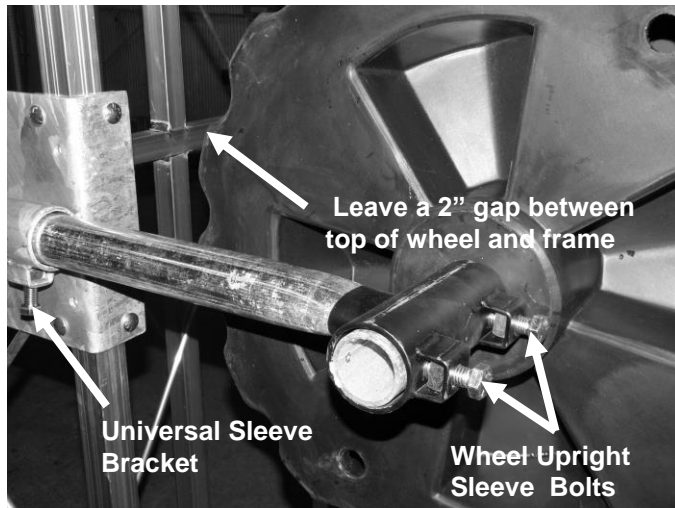

FIG. 30: Outside of Wheel Installed on Axle

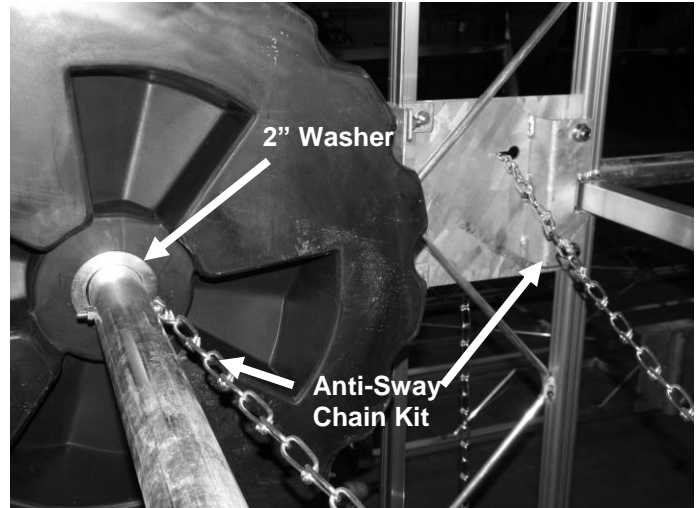

FIG. 31: Backside of Wheel Installed on Axle

ADJUST HEIGHT OF WHEEL ASSEMBLY

Slide the Axle and Wheels Assembly side to side until centered between the two Wheel Sleeve Upright Brackets. The ends of the Axle should be flush with the outside edges of the Upright Wheel Sleeve Bracket. See FIG. 30. Firmly tighten the Upright Sleeve set bolts onto the axle. See FIG. 30. Before lowering the Frame Assembly down onto wheels, firmly tighten the Universal/Upright Sleeve Bracket bolts. See FIG. 30. *Note: The Anti-Sway Chain Kit will help eliminate side to side sway in the dock. See FIG. 31.*

Your Super Platform Assembly is now complete.



FIG. 32: Install End Platform Section to Assembled Dock Sections

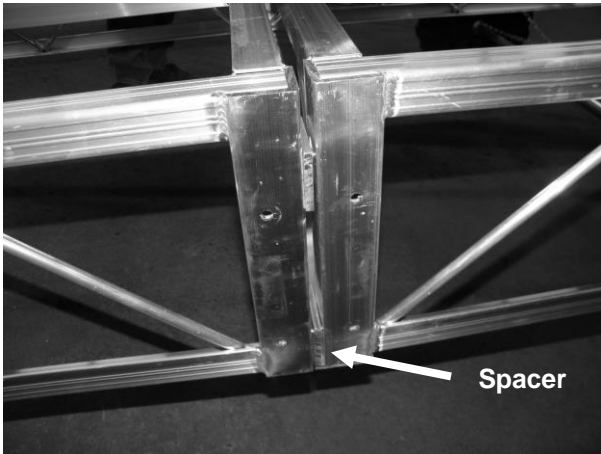

FIG. 33: Close Up of Spacer

CONNECT END PLATFORM SECTION TO DOCK SECTIONS

Connect the lake end of the assembled dock sections to the shore end of the platform assembly as shown in FIGS. 32, 33 using $\frac{1}{2}$ " x $1\frac{1}{2}$ " hex bolts and nuts.

Note the use of the spacer that keeps the section square and level. See FIG. 33.

DOCK COMPONENTS

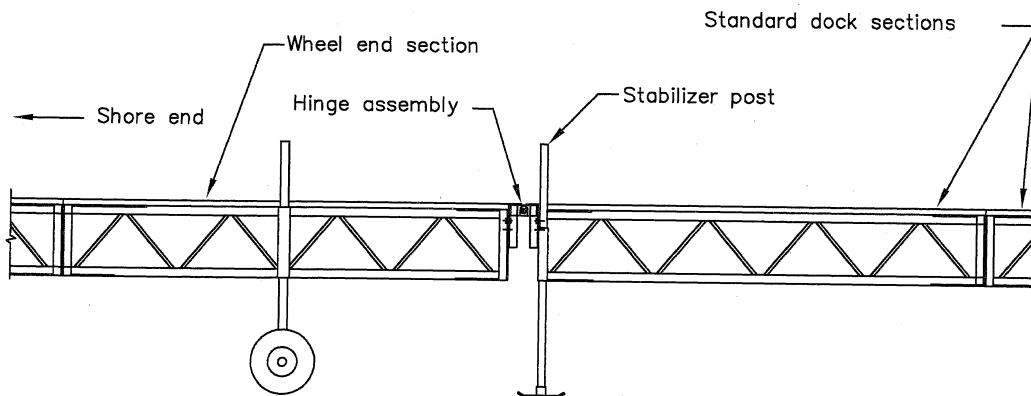

FIG. 34: Dock Components

Roll Assembled Dock into Water

- Raise all stabilizer posts to the highest position. See FIG. 34.
- Lower all wheel upright poles to the lowest position. See FIG. 34.
- Start to roll the dock assembly into the water. Raise the end platform section to a position so the dock will be level and out of the water in its final spot.

CAUTION!

TO HELP PREVENT BENDING WHEEL UPRIGHT POSTS, ALWAYS LOWER DOCK TO LOWEST POSSIBLE POSITION BEFORE PUSHING OR PULLING DOCK IN OR OUT OF WATER.

- Loosen and lower the pipe stabilizers until the foot pad is resting on the bottom of the lake.
- Using log or nearby piece of scrap wood, pound pipe into lake bottom.
- Tighten set bolt on pipe bracket. Repeat this on each pipe stabilizer assembly.
- Walk on deck to check flex, readjust pipe stabilizers if needed.
- Pipe support brackets may also be used as an effective shore end anchor system by installing a pair at the shore end of the DAKA Dock and then driving the pipes into the shore.
- For additional protection, you may wish to cover the exposed ends of pipes with plastic or rubber caps available from your DAKA Dock dealer.
- The stabilizing chains will need to be tightened after the dock has been rolled into the lake.
- With the dock level to the water, lower the end/platform end section 6" to 8" using a DAKA Winch Set (Part #1037) available from your DAKA Dock dealer. With the dock in the lowered position, reattach chains to the chain holder. Raise the dock 6" to 8", which will tighten the chains and help stabilize the dock.

INSTALLATION TIPS

- All aluminum DAKA docks up to 24' long may be installed without stabilizer pipes for use with small boats and in low-wave and wind conditions.
- If DAKA dock is to be used with any pontoon boat or sport boat in high wind or wave areas, the use of stabilizer pipes at each section joint is mandatory. Stabilizer sets #1038SS (painted) or #1038SSG (galvanized) are available for this purpose through your dealer.
- The use of a single wheel set is permitted on DAKA docks up to 40' long. Beyond 40', dock must have wheel sets located no more than 40' apart, with hinge set #1040 (painted) or #1040GA (galvanized) joining wheeled sections to next standard section.
- Failure to install stabilizer pipes, additional wheel sets and hinge sets can cause damage to DAKA dock components and possible personal injury.



www.dakadock.com